

Corporate Imaging
Firmenwerbung
Communication
visuelle



CONTENTS	Page
1.0 INTRODUCTION	3
2.0 CHANGING TRENDS IN DESIGN, SIGNS AND DISPLAY	3
3.0 PERSPEX® FROM LUCITE® PRODUCTS A COMPLETE RANGE OF BENEFITS	3
4.0 EXCITING INNOVATIONS	4
4.1 Perspex® Cast	4
4.1.1 Perspex® Edge Lighting Solutions	4
4.1.1.1 Perspex® Prismex®	4
4.1.1.2 Perspex® D-Lux	4
4.1.1.3 Perspex® S-Lux	4
4.1.2 Perspex® Frost	4
4.1.3 Perspex® 6T21 - Glass-Look	5
4.1.4 Perspex® GS Silk	5
4.1.5 Perspex® Dense colours	5
4.1.6 Perspex® GW - Glow Wire	5
4.1.7 Perspex® IM - Impact Modified	5
4.2 Perspex® Extruded	6
4.2.1 Perspex® XT 6X21 - Glass-Look	6
4.2.2 Perspex® XT Silk	6
4.2.3 Perspex® XT IM extruded sheet	6
5.0 A COMPREHENSIVE SERVICE	6
5.1 Complete Customer Support	6
5.2 Commercial and Technical Literature	6
5.3 Long Term Performance	6
5.4 Food Contact	7
5.5 Cements	7
5.6 Recycling	7
6.0 SIGNS - BETTER BY DESIGN	7
6.1 Illumination	7
6.1.1 Luminance	7
6.1.2 Light Transmission	8
6.1.3 Diffusion Factor	8
6.1.4 Lamp spacing ratio	8
6.2 Product Properties	9
6.2.1 Weathering	9
6.2.2 Light transmission properties of coloured sheet	9
7.0 FACTORS AFFECTING PERCEIVED COLOUR	9
7.1 Thickness tolerance	9
7.2 Sheet thickness	9
7.3 Surface finish	10

8.0 MECHANICAL PROPERTIES	10
8.1 Engineering design data	10
8.2 Design stress	11
8.3 Provision for sheet deflection	12
8.4 Water absorption	13
8.5 Thermal expansion	13
9.0 FASCIA DESIGN	13
9.1 Flat panels	13
9.2 Moulded panels	14
10.0 FABRICATION TECHNIQUES FOR SIGNMAKING	15
11.0 DESIGN HINTS ON SIGNMAKING WITH PERSPEX®	15
11.1 Routing and laser cutting	15
11.2 Screen printing and spray painting	16
11.3 Self-adhesive vinyl films	17
11.4 Cementing and fixing	17
11.5 Perspex® Secret Signs	17
12.0 MAINTENANCE OF PERSPEX® SIGNS	18
13.0 HEALTH AND SAFETY	18
14.0 TALK TO US	19
15.0 APPENDICES	20
15.1 Appendix I – Light Transmission Values of Perspex® GS Colours	20
15.2 Appendix II – Optical Properties of Opal/White Perspex® Grades	21
15.3 Appendix III – Outdoor Behaviour of Coloured Perspex® Sheet	21
15.4 Appendix IV - Perspex® Product Data Summary	23
15.5 Appendix V - Names and Addresses of Recommended Suppliers	24

1.0 INTRODUCTION

Around the world, brand conscious companies and organizations invest in quality signs and advertising displays to portray their image. From international companies who want to maintain a consistent corporate image, to smaller specialist outlets, they all require signs and displays that are long lasting, attractive and cost effective.

In response to their ever changing needs Perspex® from Lucite® acrylic sheet offered by Lucite International brings solutions which are eye catching, innovative, appealing and excellent value for money - key factors in today's competitive environment.

Perspex from Lucite is available in 2 main forms

- **Perspex® GS** cell cast acrylic sheet, has a high molecular weight for excellent strength, rigidity and chemical resistance. Made in a batch process it allows flexibility in colour range, surface texture and special grades
- **Perspex® XT** extruded acrylic sheet has a much lower molecular weight giving reduced mechanical properties. It does however give process advantages when heating, bending and vacuum forming, is available in longer length sheets and has a better thickness tolerance than cast sheet. Due to the automated production process, the extruded product range is more limited.

2.0 CHANGING TRENDS IN DESIGN, SIGNS AND DISPLAY

Designers and specifiers are always looking for innovative new ideas, new products or colour concepts to help them achieve and maintain their leading edge. In support of this Perspex® from Lucite® works closely with some of the leading pioneers in design, working in close partnership with the key players in the industry to make sure that a designers dream can become a brand managers reality.

We work closely with designers, specifiers and of course sign makers - collaborating on new products, new colours and new special effects right from the start of the project to its final installation. The most recent fruits of this collaboration have included a new glass look Perspex®, and the innovative new Perspex® Frost collection - amongst a host of others.

3.0 PERSPEX® PRODUCTS -A COMPLETE RANGE OF BENEFITS

- Unsurpassed outdoor weathering
- Clear sheet optical clarity better than that of glass
- Extensive choice of transparent, translucent and opaque colours and finishes
- Easy and cost effective thermoforming
- Fully recyclable
- World wide availability for consistent corporate image
- Global continuity of supply
- Precise colour matching to corporate colours
- Excellent surface hardness and durability
- Superb chemical resistance - better than most plastics
- Easy to clean and maintain
- 10 year guarantee

4.0 EXCITING INNOVATIONS

4.1 PERSPEX® FROM LUCITE® CAST

4.1.1 Perspex® Edge Lighting Solutions

A new range of Perspex® from Lucite® products has been developed to meet the changing needs of the POP, display and signs market - Perspex® Edge Lighting Solutions.

Comprising 3 products – **Perspex® Prismex®**, **Perspex® D-Lux** and **Perspex® S-Lux**, Perspex® Edge Lighting Solutions enables designers, specifiers and corporate clients to offer tailored solutions to the edge lit sign and display market - solutions which are innovative, cost efficient, environmentally friendly and stylish.

4.1.1.1 Perspex® Prismex®

Perspex® Prismex (patented edge lit technology) - the first product in the range gives the optimum performance in terms of even light and superb brightness

4.1.1.2 Perspex® D-Lux

Perspex® D-Lux gives excellent brightness and cost effectiveness - especially for smaller signs

4.1.1.3 Perspex® S-Lux

Perspex® S-Lux gives good overall illumination and can be lit from all sides - vital for larger area signs

Perspex® Edge Lighting Solutions offers a number of key benefits

- superb bright, cool, even light
- slim elegant appearance
- low energy usage and cost efficiency
- fully recyclable

For further information and literature please contact your Perspex® from Lucite® sales office or visit www.lucitesolutions.com

4.1.2 Perspex® Frost

To satisfy the current trend in design for colours and effects that are cool, translucent and subtle, Perspex® from Lucite® has developed Perspex® Frost - a new product with a cool matte surface with just a hint of lustre, and ideal for a range of POP display and POS applications.

Available in 25 fresh and contemporary colours, Perspex® Frost has all the performance characteristics designers and specifiers have come to expect from Perspex® - with the added advantage of a superb modern and stylish appearance.

The Perspex® Frost colours include

Pastel range

S2 000 Crystal Clear
S2 030 Polar White
S2 4T46 Blush Pink
S2 6T21 Glacier Green
S2 7T58 Aurora Violet
S2 7T69 Electric Blue
S2 7T77 Arctic Blue

Vivid range

S2 2T53 Saffron Yellow
S2 3T37 Burnt Orange
S2 4T97 Raspberry Red
S2 6T9A Lime Zest
S2 7T1F Azure Blue
S2 8T14 Violet Heather
S2 8T15 Perfect Plum

Hot range

S2 2T07 Citrus Yellow
S2 3T17 Mandarin Orange
S2 4T50 Chilli Red
S2 6T7A Jade Green
S2 7T28 Sapphire blue

Urban range

S2 1T41 Moonlight White
S2 5T18 Sandstone Brown
S2 5T33 Earth Brown
S2 9221 Midnight Black
S2 9T21 Stone Grey
S2 9T23 Slate Grey

4.1.3 Perspex® 6T21 - Glass-Look

This special grade of Perspex® from Lucite® was developed to provide a “Glass look” product to offer designers all the benefits of cast acrylic whilst giving the appearance of glass. It provides the perfect choice in today’s modern displays where clean lines and a minimal appearance are required.

With half the weight of glass and less of the breakage problems, Perspex® 6T21 Glass- Look is the ideal alternative to glass - it gives greater flexibility and can be easily machined fabricated and installed.

4.1.4 Perspex® GS Silk

Designers have long enjoyed the benefits of using Perspex® GS Silk in sign programmes where the performance of cast sheet is required but a more subtle smooth finish is required - a combination found perfectly in Perspex® GS Silk.

4.1.5 Perspex® - Dense colours

Perspex® dense white - 1209 - has been developed as a more cost effective option for non illuminated letters or fascias. It has much lower light transmission than Perspex® opal/white 069 and is available in a range of thickness. Other dense colours are available on request.

4.1.6 Perspex® GW - Glow Wire

With improved glow wire performance **Perspex® GW** meets and exceeds the needs of a typical emergency lighting application. Perspex® GW also gives excellent clarity, superb UV resistance and can be easily thermoformed.

4.1.7 Perspex® IM - Impact Modified

Perspex® cast IM sheet is strong and tough with an impact resistance 10 times greater than that of glass and is ideally suited to the most demanding applications.

Perspex® cast IM is available in a full range of clear opal and colour options and in both high gloss and Silk finishes. It offers all the benefits of cast sheet - including excellent chemical resistance and a better fire performance than that of extruded acrylic sheet.

4.2 PERSPEX® EXTRUDED

4.2.1 Perspex® XT 6X21 GLASS-LOOK

This extruded sheet grade of **PERSPEX® - 6X21 Glass-Look** has been developed to give designers and sign makers the appearance of glass combined with the performance properties of extruded acrylic sheet. This gives excellent shaping, vacuum forming and fabrication and is a more flexible alternative to glass.

4.2.2 Perspex® XT Silk

A new grade of Perspex® - **Perspex® XT Silk** has been introduced to give the smooth subtle Silk finish that is a required feature of today's design. Perspex® XT Silk gives improved vacuum forming and greater cost effectiveness for applications as diverse as signs, picture frames, poster boxes and many more.

4.2.3 Perspex® XT IM extruded sheet

Perspex® from Lucite® impact modified extruded sheet is available in 2 variants - **Perspex® XT IM 50** and **Perspex® XT IM 60** - which give high and very high impact resistance respectively. Both grades give improved impact resistance to that of standard extruded sheet, whilst retaining excellent edge clarity, good abrasion resistance and high rigidity.

Perspex® XT IM sheet can be thermoformed faster than many competitive products whilst retaining excellent forming characteristics.

5.0 A COMPREHENSIVE SERVICE

5.1 COMPLETE CUSTOMER SUPPORT

Lucite International offers a complete technical and commercial support service, using its world wide network of commercial and technical centers, sales offices and of course agents and officially appointed distributors.

5.2 COMMERCIAL AND TECHNICAL LITERATURE

We offer a range of commercial and technical product literature to suit most needs - and of course you can always contact us at our Perspex® from Lucite® sales office for further assistance.

The following items are our key pieces of literature

- **602 - Perspex® from Lucite® product range** - full information on all products in the range
- **132 - Workshop Handbook** - everything the practitioner needs to know about fabricating Perspex®
- **302 - Perspex® Product data summary** - a summary of Perspex® technical data

Copies of these and other product literature can be obtained from the Knowledge Bank via our Website www.lucitesolutions.com/knowledgebase

5.3 LONG TERM PERFORMANCE

All Perspex® from Lucite® products have been formulated to give excellent performance for a long time - and particularly for the expected life of a sign. We offer a

10 year guarantee for most grades of Perspex® - including clear opal and coloured products - for further information contact your Perspex® from Lucite® sales office or visit www.lucitesolutions.com

5.4 FOOD CONTACT

The monomers used in the production of Perspex® sheet meet the European Directive (90/128/EEC) relating to plastic products intended for use in food contact applications. For further information please contact your Perspex® from Lucite® sales office.

5.5 CEMENTS

Tensol® cements, originally developed for use with Perspex®, and ideal for fabricating sign components are supplied by Bostik® Ltd. Further information on these cements is available from Bostik® and can also be found together with information on other adhesives in our documentation **232 - Workshop Handbook**.

5.6 RECYCLING

Perspex® from Lucite® acrylic sheet can be fully recycled back to its original monomer. For further information on recycling Perspex® sheet please contact your Perspex® from Lucite® sales office.

6.0 SIGNS - BETTER BY DESIGN

6.1 ILLUMINATION

Lighting an internally illuminated sign made from Perspex® from Lucite® acrylic sheet requires careful consideration to achieve maximum visual impact. With the wide range of available colours of Perspex® sheet and the many different types of lamps, it is not possible to present a simple set of rules which assures the most effective results for every individual sign design.

For most types of sign however the method of lighting is predictable and general guidelines are given in this booklet which will enable the designer to create aesthetic appeal combined with a suitable level of luminance. Where a sign is of unusual design it may be necessary to construct an experimental prototype in order to establish the most effective means of illumination.

For details of lamps, electrical gear and additional technical support on lighting design the lamp manufacturer should be consulted. Names and addresses of lamp suppliers are given in Appendix V.

6.1.1 Luminance

The term luminance is used to describe the measured brightness of a point on a surface, when viewed in a given direction. Of the various photometric concepts, luminance is the one which is most relevant to the design of an illuminated sign. In the following paragraphs the concept of luminance and its applications are described in practical terms.

For the purpose of considering glare in relation to luminance it is best to consider luminance as "brightness" in the simple sense. The degree of glare caused by a sign depends on many other factors as well as its brightness. These include its size, colour, its position relative to the direction from which it is seen, the brightness of its surroundings and the age and maintenance of the sign. A sign mounted in a well lit city street will appear less bright than the same sign seen in the darkness of the countryside. The sign must therefore be bright enough to command attention but not

so bright as to cause annoyance to local residents or distract the attention of motorists.

To decide on the very complex problem of how bright a sign should be in any particular location reference should be made to a report entitled Technical Report No.5 ,“Brightness of Illuminated Advertisements”, copies of which can be obtained from the Institution of Lighting Engineers, Lennox House, 9 Lawford Road, Rugby, CV21 2DZ.

The luminance of any internally illuminated sign or fascia is determined by five factors:-

1. **Lamps** - their number, type, light output, colour and position in the sign case.
2. **Materials** - the light transmission, reflection, absorption and diffusion factors of the Perspex® from Lucite® grade and thickness used.
3. **The Sign Case** - its dimension, particularly its depth and the reflection factor of the paint or other finish used on the inside of the case.
4. **Light Absorption** - the effect of absorption of light by the lamps and electrical equipment within the case.
5. **Maintenance** - the reduction in the light output of the lamps with increasing age and the influence of dust inside the case.

6.1.2 Light Transmission

Planning authorities often apply a simple formula to assess the brightness of a sign to ensure it conforms to the agreed limits and this requires the light transmittance value of the signmaking material. The light transmission values of all Opal/White grades and most of the popular Perspex® from Lucite® sign colours are listed in **Appendices I and II**.

6.1.3 Diffusion Factor

When designing signs made from Perspex® from Lucite® sheet, consideration must be given to the diffusion factor of the chosen colour. A good diffuser when illuminated will scatter direct or transmitted light uniformly in all directions. The calculated diffusion factors for most of the Opal/White grades of Perspex® are listed in **Appendix II**.

If a material has a diffusion factor of between 0.82 and 0.89 it can be considered to have maximum degree of diffusion. All Opal/White Perspex® sheet grades have excellent diffusion except Opal/White 030 and Opal/White 1X70 which are designed to give high light transmission with only moderate diffusion. Most translucent Perspex® colours have diffusion factors in excess of 0.80 and can be considered to be good diffusers.

6.1.4 Lamp Spacing ratio

Uniform illuminance of a sign made from Perspex® from Lucite® sheet is dependent on the diffusion factor of the Perspex® grade and the lamp spacing. Generally if the diffusion factor is over 0.80, a lamp spacing ratio of 1 to 1.5 should prove satisfactory. This ratio is calculated as follows:

$$\text{Lamp spacing ratio} = \frac{\text{Distance between lamp centers}}{\text{Distance from lamp centre to Perspex® sheet}}$$

If a number of different colours are used in one sign then no fixed rule can be applied to obtain the level and uniformity of luminance required and a prototype should be constructed to confirm the desired effect.

A prototype sign will also ensure that the correct complementary colour balance will be achieved between the different illuminated colours without any unexpected and unwanted visual colour distortions.

6.2 PRODUCT PROPERTIES

6.2.1 Weathering

Most grades of Perspex® from Lucite® acrylic sheet have outstanding resistance to outdoor weathering and can be considered amongst the best of all plastics materials. Under normal exposure conditions, correctly fabricated self-coloured signs made from Perspex® will not lose mechanical strength over a typical design life of 10 years exposure outdoors in Europe. Lucite International offers a 10 year guarantee on the mechanical performance of its standard Perspex® acrylic sheets, and copies of this document may be obtained from the Knowledge Bank on www.lucitesolutions.com

Full details of the outdoor performance of typical Perspex® colours are given in **Appendix III**.

6.2.2 Light Transmission Properties of Coloured Sheet

Perspex® from Lucite® sheet is produced to the highest quality standards which ensure colour consistency from batch to batch and sheet to sheet. Since the colour extends throughout the thickness of the sheet, scuff and scratch marks have little effect on the appearance of illuminated colours in a sign.

Most coloured Perspex® sheet is produced so that the light transmission decreases with increasing thickness. However, for those sign applications where this effect would not be appropriate, i.e. where different sheet thicknesses of a colour may be needed on the same sign, Constant Transmission (CT) colours are available giving the same colour transmission irrespective of sheet thickness. CT Colours are identified by the letter "T" in the colour reference number, e.g. Opal/White 1T02, Red 4T17.

7.0 FACTORS AFFECTING PERCEIVED COLOUR

7.1 Thickness Tolerance

Cast acrylic sheet has a manufacturing thickness tolerance, which can reveal some variation in colour by transmitted light at opposite ends of the tolerance. This effect, inherent in the cell-casting manufacturing process, can therefore reveal slight changes in hue between certain dark colours such as greens and blues even though the thickness difference may only be fractions of a millimeter. Such slight differences in transmitted colour are most noticeable when two fascia panels are cut from different sheets and butted up together.

It is therefore strongly recommended that when making fascia signs, the cut panels are colour balanced on a full sized light box to ensure uniformity of illuminated colour. If this is not possible, thickness measurements should be taken at the butt edges and the panels aligned to give as near uniform thickness as possible across the butt joints to ensure colour uniformity before any fret cutting or cementing.

7.2 Sheet Thickness

With standard colours an increase in sheet thickness can be used to reduce the brightness of a sign. Some colour change may occur by transmitted light but the difference by reflected light will be minimal.

7.3 Surface Finish

When using Perspex® Silk, reflected colours will be slightly lighter as a result of the light scattering effect of the textured surface.

8.0 MECHANICAL PROPERTIES

8.1 Engineering Design Data

When designing a sign using Perspex® from Lucite® sheet, it is important that the mechanical characteristics of the material are taken into account. No attempt will be made here to cover all aspects of sign design, only the important features particular to Perspex® acrylic sheet will be considered.

It is vitally important - especially when designing large signs - that due consideration is given to wind-loading on vertical surfaces and an allowance must be made not only for normal conditions but also for exceptional short-term wind forces that may occur during the lifetime of the sign. National standards exist in most countries for wind load requirements on buildings.

Most design formulae available to design engineers make two assumptions when considering conventional materials such as metals:

1. The material has a linear stress/strain curve
2. The deflections induced during load conditions are small

Many thermoplastic materials generally do not have linear stress/strain curves but these conditions may be reasonably satisfied with Perspex® from Lucite® provided that certain restrictions are imposed. **Figures 1 and 2** illustrate the design stress and design modulus of cast Perspex® sheet and it will be noticed that these values are dependent on temperature. Consequently the anticipated maximum service temperature of the sign must be known before it can be designed.

Figure 1 Design Modulus for Perspex® GS cast acrylic sheet as a function of temperature

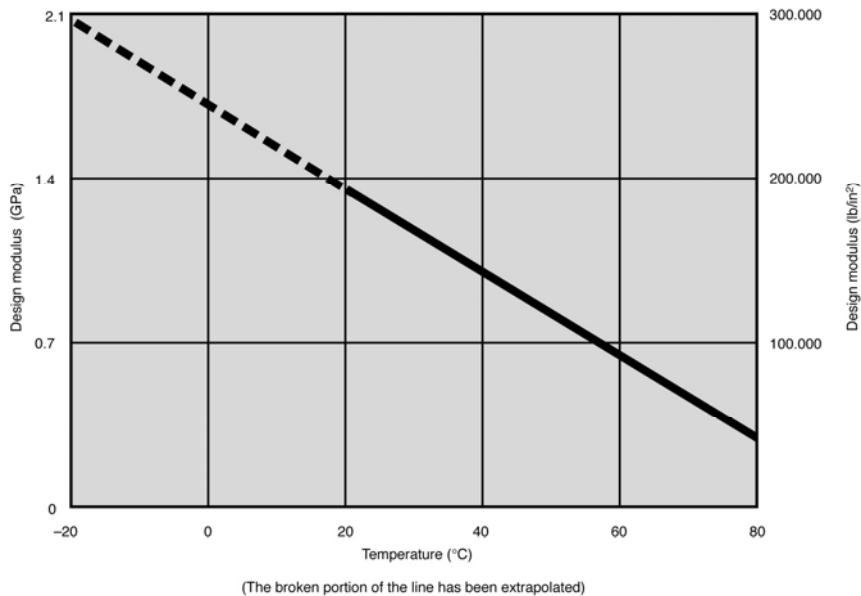
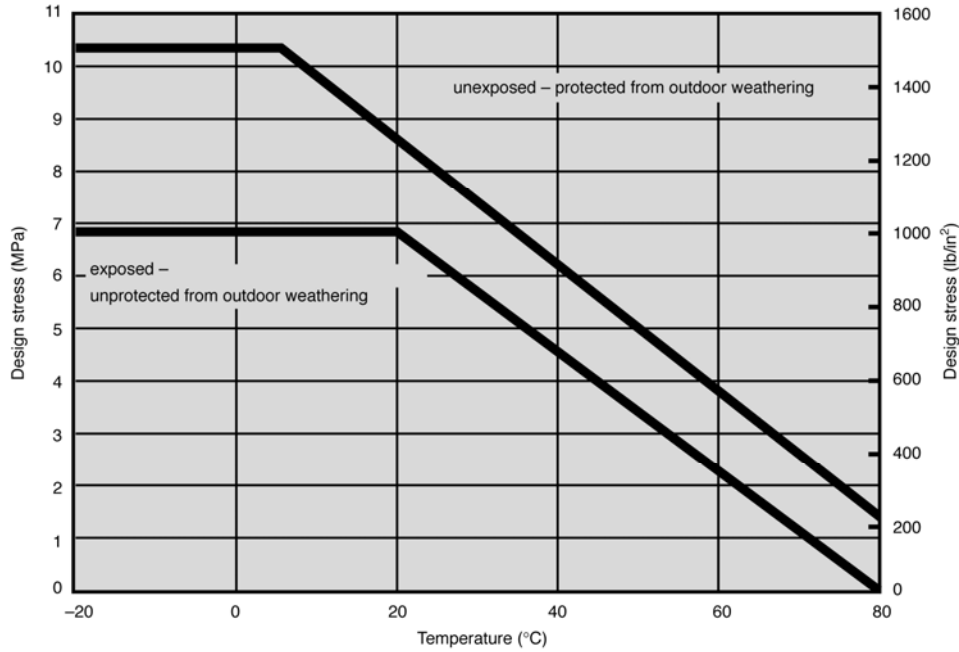

Figure 2 Design stress for Perspex® GS cast acrylic sheet as a function of temperature



8.2 Design Stress

The stress/strain curves for standard Perspex® from Lucite® sheet grades within the normal service temperature range are almost linear for strains up to 1%. Since the recommended design stresses are such that this strain is never exceeded even after allowing for creep, the problem of nonlinearity is immediately solved. However, considerations of design stress do not take into account the question of the large deflections which may occur in bend because of the low Young's modulus of a typical thermoplastic material like Perspex®. The problem of large deflections may be overcome in two ways:-

1. The first and most obvious is to apply large deflection theory, but this is complicated and in many instances formulae for thermoplastics are not readily available.
2. The second and preferred method is to apply the simpler small deflection theory. Instead of considering design from the point of view of stresses produced in the material by wind loading the deflections produced are considered first and a restriction imposed on the permissible deflection. This treatment has the added advantage that signs maintain a good appearance even under wind loading and are less likely to "blow out" of their securing frames.

The restriction applied is that the ultimate deflection shall not exceed the thickness of the material since at this low level of deflection the membrane stresses produced in the surface under tension are small.

For these reasons it is strongly recommended that when designing signs made from Perspex® from Lucite®, the use of small deflection theory is applied. **Table 1** gives the important mechanical properties of cast Perspex® sheet for design calculations.

Table 1 Properties of Perspex® GS cast sheet important in mechanical design

PROPERTY	UNITS	VALUE*	TEST METHOD
Design modulus		see Figure 1	ISO 1183/A DIN 53752 (0-50°C)
Design stress		see Figure 2	
Poisson's Ratio at 20°C		0.38	
Density	g/cm ³	1.19	
Coefficient of linear thermal expansion	K ⁻¹	7.7 x 10 ⁻⁵	
Dimensional allowance due to water absorption	% length	0.3	

* These are typical values obtained from representative samples of Perspex® cast sheet and do not constitute a specification.

8.3 Provision for Sheet Deflection

Deflection may occur as a result of wind loading or from the static load of the sheet itself. It is therefore important that suitable precautions are taken to avoid this effect becoming too extreme.

Fortunately experience gathered over a great many years has lead to certain guidelines being drawn concerning the recommended thickness of Perspex® from Lucite® sheet that may be safely used for a given sign dimension under maximum wind load conditions, without the need for frequent calculation.

Table 2 provides an indication of the minimum recommended thicknesses of Perspex® sheet in relation to panel size for a fascia sign for example. These thicknesses assume a maximum wind load of 50 meters per second. The panel dimensions are for the narrow axis.

Table 2 Thickness of standard Perspex® sheets for signs panels to withstand a wind velocity of 50 m/sec.

SHORTEST PANEL DIMENSION (USUALLY HEIGHT) (mm)	THICKNESS OF PERSPEX® (mm)
Up to 400	3
400-600	4
600-750	5
900 – 1200	8
1200 – 1500	12
1500 – 2000	15

NOTE:

If large signs are to be made and for design or economic reasons the recommended thickness of sheet cannot be used, the Perspex[®] from Lucite[®] panels must be reinforced to prevent excessive deflection and possible breakage during gale force winds. It is difficult to give precise details concerning the degree of reinforcement required but as a general rule, bracing strips of thick clear Perspex[®] should be cemented at right angles to the back face of the sign panel at approximately 600 mm distances to provide extra rigidity. Anti-deflection studs fixed to the back surface of the sign box at regular intervals should also be considered for large sign pans or fascias likely to be subjected to high wind loading, e.g. display signs located on the top of tall buildings.

8.4 Water Absorption

Acrylic sheet may absorb up to 2% of water over long periods and this absorption can result in dimensional changes in the sign. The level of absorption and the dimensional change depends on the relative humidity of the atmosphere and the initial water content of the sheet. As a general rule, 100% relative humidity can result in a dimensional increase of 0.3% and due allowance should be made for any possible expansion to avoid distortions occurring in the sign.

Perspex[®] XT extruded acrylic sheet can exhibit slightly more dimensional change in humid environments due to the lower initial moisture content of extruded sheet.

8.5 Thermal Expansion

The coefficient of linear thermal expansion of thermoplastic materials is greater than that of most other materials and therefore where significant variations in temperature are expected during the service use of the sign, an allowance must be made for thermal movement of the material.

When Perspex[®] from Lucite[®] sheet is to be used for external signs adequate allowance must be made for thermal expansion and contraction during the design and construction of the sign. In Europe, external signs can be subjected to extremes of temperature from -20°C in winter to +30°C in summer, a temperature variation of 50°C. From many years practical experience it has been found that as a general rule, an expansion allowance of 0.5%, or 5 mm per meter run length, on both panel dimensions should be sufficient to accommodate any temperature and humidity variations.

It is equally important to bear in mind that when fixing Perspex[®] sign panels into frames the rebate depth of the framing must be sufficient not only to accept the expansion clearance but also an equivalent contraction allowance, otherwise, panels could be blown out of their frames in gale force winds during the winter months.

9.0 FASCIA DESIGN

9.1 Flat Panels

It is recommended that all sign fascia made from Perspex[®] from Lucite[®] greater than 600 mm in height should be “top-hung” in suitably designed signbox sections, to avoid undue deflection due to self-loading stresses. In order to top hang Perspex[®] sign panels, strips of Perspex[®] must be cemented or otherwise fixed to the top edge of the panel to provide a top hanging bar that will sit securely in the signbox framing. All the load is then taken on this top edge leaving an expansion clearance on the

bottom edge. For long term reliability and safety, a polymerising cement such as Tensol® No. 70 should be used for all cementing work. The signbox should be designed such that in the event of any failure of the top hanging bar the panel will not fall out of the framing. **Figure 3** illustrates a typical design of top hanging bar suitable for Perspex®.

Figure 3 A typical design for top hanging bar

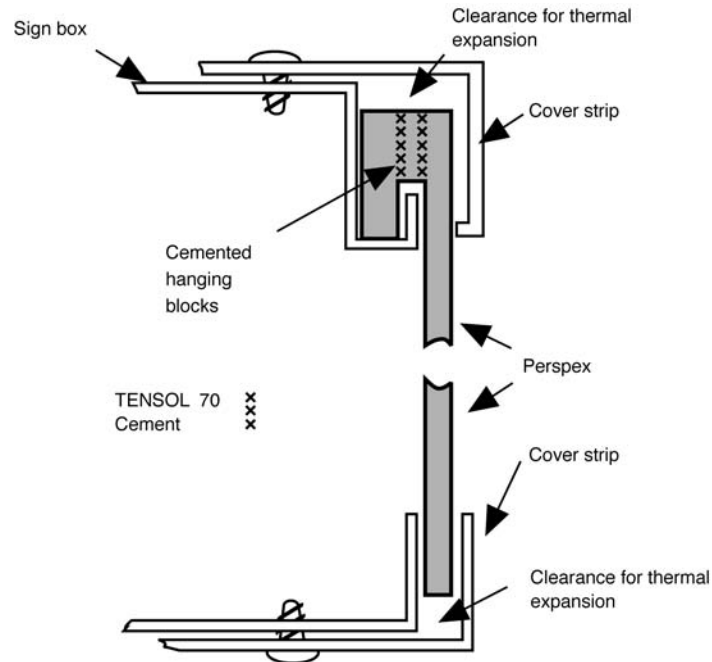

Where it is necessary to join Perspex® from Lucite® panels together it is recommended that the butt edges are overlapped by the use of machined half-lapped or step-lapped joints to avoid light loss through the edges. For very long fascias where it is necessary to join several horizontal Perspex® panels together, expansion clearances should be provided at each half-lapped edge in accordance with the recommendations given earlier. To prevent undue sideways movement of the individual panels, securing pins should be inserted in the center top edge of each panel into the signbox frame to equalize thermal movement in each sideways direction and to prevent gaps appearing with light loss at the edges.

For sign fascias up to 600 mm in height, conventional framing may be used and 3 or 5 mm Perspex® sheet used. Where complete freedom from optical distortion arising from self-loading is required, 5 mm sheet is recommended.

9.2 Moulded Panels

Moulded sign pans made from Perspex® from Lucite® are usually more rigid than flat sheet and thinner sheet than the recommendations given in **Table 2** can sometimes be considered when thermoforming sign pans. It is difficult to give precise recommendations for moulded pans because these will depend on the design of the moulding, the use of moulded or cemented letters and the draw ratio. When considering thickness of sheet to withstand wind loading, however, it should always be borne in mind that sheet section diminishes in relation to the depth of draw used.

10.0 FABRICATION TECHNIQUES FOR SIGNMAKING

The fabrication of Perspex® from Lucite® (cutting, machining, thermoforming and polishing) for signmaking follows conventional techniques for acrylic sheet and full details are given in **232, Workshop Handbook**.

11.0 DESIGN HINTS ON SIGNMAKING WITH PERSPEX® SHEET

11.1 Router or Laser Cutting Inlaid Sign Components

By taking full advantage of the colour range available, Perspex® from Lucite® signs may be built up by either routing or laser cutting design logos and letters from several colours, and inlaying these into sign fascias or panels of opal or coloured Perspex® using Tensol® cement No. 70.

Tremendous scope for artistic design can be derived by using combinations of coloured sheet of different thicknesses with clear Perspex® block and patterned sheet. This method of signmaking makes possible striking lighting effects using the halo principle and in general the illuminated colour is superior to that of other methods of signmaking.

Figures 4 and 5 illustrate typical CNC router and laser cutting machines in regular use in the sign industry.

Figure 4 The Pacer router supplied by Pacer Systems Ltd.



Figure 5 The Gerber router supplied by Spandex plc.



Laser cutting machines offer certain advantages when cutting Perspex[®] from Lucite[®] sign components, e.g. polished edges and sharp detail, but because of the intense heat generated in the immediate localized area stress crazing can sometimes occur at the cut edge when cementing. To eliminate the risk of stress crazing, especially with extruded components, it is recommended that laser cut parts are given a short annealing cycle of one hour at 80°C before cementing.

11.2 Screen printing and spray-painting

Excellent internally illuminated signs can be made by applying surface decoration to Perspex[®] from Lucite[®] sheet by either screen-printing or spray painting. These techniques offer certain advantages: -

- a wide variety of colours are readily available in small quantities
- the need for fret cutting and cementing is eliminated
- designs may be applied to the reverse surface of clear sheet to give greater protection from scratches
- lower item costs

However it is difficult, especially when making large signs, to maintain colour uniformity when viewed by transmitted light. Also, spray painting is a highly skilled technique. From experience, surface decorated signs rarely achieve the intense depth of illuminated colour of self-coloured Perspex[®] inlaid signs and are also less resistant to the damaging effects of weathering and repeated handling during maintenance.

For satisfactory weathering and service life, specially formulated ink and paint systems are necessary. Pigments and dyes used must be stable to ultra-violet light and the resin systems used must be stable and compatible with acrylic sheet. It is essential therefore to use only those products that have been formulated and tested for use with Perspex® from Lucite®. Experience and testing have shown that only acrylic based screen printing inks and paints are suitable for long term exposure outdoors. Cellulose based products are not recommended for use in contact with Perspex®, and solvent thinners must also be compatible with acrylic sheet. Stress in acrylic sheet can cause surface crazing or cracking when screen print is applied unless suitable precautions are taken. It is therefore important to ensure that all moulded sign pans are stress-free before screen printing. For further details on the moulding or thermoforming of Perspex® please refer to **232, Workshop Handbook**.

11.3 Self-adhesive vinyl films

Coloured designs and letters can be applied to Perspex® from Lucite® to make signs using self-adhesive vinyl films. These products are usually translucent, light transmitting films. In recent years, the use of vinyl films has become extremely popular following the development of small, high speed plotting and cutting machines. Designs can be quickly scanned or drawn using CAD techniques. This method of sign making lends itself well to low cost production of short runs.

As in the case of screen printing and spray painting it is essential for users to ensure that the vinyl film products chosen are suitable for use in contact with Perspex® and are formulated for long term outdoor exposure.

11.4 Cementing and fixing

When building-up letters or signboxes from Perspex® from Lucite® parts it is the usual practice to use Tensol® cement supplied by Bostik Ltd. A summary of which of their cements and adhesives is best suited to fixing Perspex® both to itself and to other materials is contained in **232, Workshop Handbook**. For comprehensive guidance on cementing as well as Health and Safety information, please contact Bostik Ltd., whose address and telephone number can be found in Appendix V.

The use of bolts and screws is not normally recommended for securing Perspex® sheet. If such methods must be used, care must be taken to ensure that adequate allowance is made for thermal expansion and contraction. Oversized holes must be drilled and screws must not be over tightened. Self-locking nuts should be used and the use of cup washers is recommended to assist in spreading loads.

11.5 Perspex® Secret Signs

Perspex® Secret Signs are small self-contained units that display a readable message only when illuminated. Their purpose is to provide a message or instruction at intermittent times during the day. They are used in banks, building societies, airports, etc, when clear instructions need to be given, e.g. "CAR PARK FULL" or "BOARDING GATE 5".

Lucite International offers a special cast sheet Silk finish grade, **Perspex® Black 'n' White 9T25**, for secret sign construction in which the combination of special pigments to achieve the desired effect is provided in a single sheet. Perspex® 9T25 will present an anti-reflective black surface when unlit which then transmits white light on illumination. The application of a suitable opaque stencil or graphics to the reverse surface will then provide a simple, white-lit, secret sign.

The light transmission of 9T25 is lower than that of typical Perspex[®] from Lucite[®] sign colours and so more intense lighting will be needed to achieve good illumination. Fluorescent lamps are the preferred type of lighting. As a general rule, twice the number of lamps are likely to be needed for secret signs compared to conventional Perspex[®] signs in order to achieve the desired level of illumination.

Note that for outdoor use, Perspex[®] Secret Signs will not be visible in normal daylight conditions. It will therefore be necessary to fit cowling around the top and side edges of the signbox, to place the sign panel in deep shade in order to increase the visibility of the illuminated message.

Stencils will be needed to produce the graphics and these are best produced by applying opaque self-adhesive vinyl film to the reverse surface of the secret sign. In this instance, stencils must be cut in the reverse image. For large numbers of signs, or if a variety of coloured graphics are required, screen printing may be a more economical alternative.

Many design possibilities exist with Perspex[®] Secret Signs. For example, by applying self-adhesive translucent coloured vinyl films to the rear surface an extremely wide range of coloured graphics become possible.

Perspex[®] Secret Sign grade is normally supplied in 3 mm thick sheet, in order to achieve the best illuminated definition of reverse applied graphics. Although secret signs are not recommended for large outdoor signs, designs over 600 mm in dimension would need to be reinforced on the back surface to withstand wind loading if located outdoors.

12.0 MAINTENANCE OF PERSPEX SIGNS

Although Perspex[®] GS gloss finish acrylic sheet is virtually self cleaning, certain finishes such as Silk may require periodic cleaning to assist in retaining the quality appearance. Signs are best cleaned using a soft brush or cloth with fresh water to which a little detergent has been added. Under no circumstances should methylated spirits nor solvent be used to clean Perspex[®] from Lucite[®] signs. Proprietary cleaning solutions should only be used if they are known to be compatible with acrylic sheet. Abrasive cleaners of any kind should never be used on Perspex[®] sheet.

13.0 HEALTH AND SAFETY

Details of the correct techniques and safe working practices when fabricating Perspex[®] from Lucite[®] for signs are given in **232, Workshop Handbook**.

Perspex[®] signs are not generally controlled by statutory fire and flammability regulations in outdoor locations other than petrol retail forecourts in the UK. Legislative controls may exist for certain indoor locations in some countries. All grades of Perspex[®] can ignite and if ignited will continue to burn.

Please refer to the appropriate **MSDS** (Material Safety Data Sheet) for Safety, Health and Environmental information, as advised below.

Users of Perspex[®] are recommended to consult the appropriate Lucite International **MSDS** which is obtainable from your supplier. Users of other materials mentioned in this publication but not produced by Lucite International are advised to obtain Health and Safety information from the suppliers.

14.0 TALK TO US

Tel: +44 (0)1254 874 000
info@lucitesolutions.com
www.lucitesolutions.com

Lucite International UK Ltd
PO Box 34
Darwen
Lancs BB3 1QB
Fax: 01254 873 300



No part of this document either text or graphics, may be reproduced in any form without written permission from Lucite International.

Values quoted for properties of Perspex® from Lucite® are results of tests on representative samples and do not constitute a specification.

Information contained in this publication or as otherwise supplied to users is believed to be accurate and is given in good faith, but it is for the users to satisfy themselves of the suitability of the product for their own particular purpose. Lucite International gives no warranty as to the fitness of the product for any particular purpose and any implied warranty or condition (statutory or otherwise) is excluded except to the extent that exclusion is prevented by law. Lucite International accepts no liability for loss or damage (other than that arising from death or personal injury caused by defective product, if proved), resulting from reliance on this information. Freedom under Patent, Copyright and registered Designs cannot be assumed.

Perspex® Lucite® and Tensol® are registered Trade Marks of Lucite International.

Our general selling conditions apply.

© Lucite International UK Ltd 2005

15.0 Appendices

15.1 Appendix I – Light Transmission Values of 3 mm Perspex® GS Sign Colours

Perspex® GS Grade	% Light Transmission (380-780 nm)
Clear 000	92
Cream 128	16
Cream 133	32
Yellow 229	21
Yellow 250	34
Yellow 260	19
Yellow 261	31
Yellow 2252	25
Amber 300	48
Orange 324	20
Orange 363	5
Red 431	3
Red 433	3
Red 440	4
Red 4238	2
Red 4401	10
Red 4403	9
Red 4450	9
Red 4494	1
Brown 504	58
Brown 543	0
Green 606	67
Green 635	11
Green 650	3
Green 692	18
Blue 706	67
Blue 727	4
Blue 743	3
Blue 744	<1
Blue 750	1
Blue 751	1
Blue 7703	5,5
Violett 886	5
Neutral 901	61
Neutral 923	11
Neutral 9T01	50
Neutral 9T13	54
Neutral 9T20	40
Black 962	0
Black 9T30	0,1
Black 9T32 (961)	0
Grey 9981	5,5

Note:-

- (1) Figures in brackets refer to previous colour codes.
- (2) Light transmission measurements have been measured on apparatus conforming to ASTM D 1003, Illuminant C. (Values to Illuminant D65 are virtually identical in most instances.)
- (3) All figures quoted are the results of tests on typical samples and do not constitute a specification.

>>

- (4) The above figures are for typical standard colours and are only a small representation of the Perspex® from Lucite® colour range. For details of other colours, or the procedure for ordering special colours, please contact your nearest Perspex® from Lucite® sales office.

15.2 APPENDIX II PERSPEX® OPTICAL PROPERTIES OF 3 MM OPAL/WHITE

Grade	% Light Transmission	% Reflection	Diffusion Factor
Perspex® GS			
Opal/White 028	26	74	0,89
Opal/ White 030	65	25	0,46
Opal/ White 040	49	39	0,87
Opal/ White 041	49	39	0,83
Opal/ White 050	35	61	0,89
Opal/ White 069	9	91	0,89
Opal/White 1209	<1	-	-
Perspex® XT			
Opal/ White 1X10	28	69	0,87
Opal/ White 1X20	41	52	0,85
Opal/ White 1X30	45	48	0,75
Opal/ White 1X70	79	-	-

15.3 APPENDIX III - OUTDOOR BEHAVIOUR OF COLOURED PERSPEX SHEET

The table on page 22 gives estimates for the typical behavior of many coloured grades of Perspex® from Lucite® when exposed outdoors. The times indicated are for the estimated service life of the product in temperate and tropical climates.

During long-term exposure outdoors, especially in tropical climates, all painted surfaces, self-coloured materials and even natural materials such as stone can be expected to show some colour change with time.

The definition of “service life” is therefore that period of exposure under normal conditions during which any colour change which may occur will remain unnoticed by the casual observer from street level.

It is important to note that new panels of Perspex® installed alongside older panels of the same colour which have been exposed for some time will almost certainly display a difference in colour. This is quite normal for most coloured surfaces and cannot be avoided.

The following estimates are for 3 mm un-moulded sheets mounted vertically and facing the noon-day sun. Temperate climate estimates have been derived from tests conducted at Welwyn Garden City and Teesside, UK. Tropical climate tests have been conducted on test stations in Calcutta, India and South Australia.

COLOUR	CLIMATE (YEARS)		COLOUR	CLIMATE (YEARS)	
	TEMPERATE	TROPICAL		TEMPERATE	TROPICAL
Opal/White 028/1T02	≥10	≥10	Green 692	10	5
Opal/White 030	≥10	10	Green 6205	7	5
Opal/White 040	≥10	≥10	Green 6600	≥ 10	≥10
Opal/White 050	≥10	≥10	Green 6605	10	7
Opal/White 069	≥10	10	Green 6633	≥10	10
Opal/White 1T04	≥10	10	Green 6634	7-10	5
Opal/White 1X10	≥10	10	Green 6643	5-7	3
Opal/White 1X20	≥10	10	Green 6X05	5-7	3
Opal/White 1X30	≥10	10	Blue 706	7	3-5
Opal/White 1X70*	≥10	10	Blue 724	≥10	7
Cream 128	≥10	10	Blue 727	10	5
Ivory 133	≥10	10	Blue 743	7	3
Yellow 229	≥10	10	Blue 744	≥10	5
Yellow 250	≥10	≥10	Blue 750	≥10	7
Yellow 260	≥10	10	Blue 751	≥10	10
Yellow 261	10	5-7	Blue 7700	≥10	7-10
Yellow 2252	≥10	10	Blue 7703	≥10	10
Yellow 2T04	≥10	10	Blue 7704	7-10	3-5
Yellow 2T07	10	7-10	Blue 7748	10	5-7
Amber 300	10	5-7	Blue 7T02	10	5
Orange 324	10	7-10	Blue 7T03	3	NR
Orange 363	≥10	10	Neutral 901	10	7
Red 431	7	5	Neutral 914	≥10	≥10
Red 433	7	5	Neutral 923	10	5
Red 440	≥10	10	Neutral 9T11	10	7
Red 4401	5-7	5	Neutral 9T13	5	2-3
Red 4403	7	5	Neutral 9T14	≥10	≥10
Red 4404	5-7	5	Neutral 9T16	≥10	≥10
Red 4450	3-5	NR	Neutral 9T19	≥10	10
Red 4494	10	5	Neutral 9T20	10	5-7
Red 4T12	5-7	5	Neutral 9T23	10	5
Red 4T17	7-10	5	Neutral 9X05	5	2
Red 4T26	≥10	10	Neutral 9X14	10	7-10
Brown 504	10	5	Black 960	10	7-10
Brown 506	10	7-10	Black 962	≥10	≥10
Brown 543	≥10	10	Black 9961	7-10	5
Brown 581	≥10	10	Black 9T30	10	7-10
Brown 5T06	10	7-10	Grey 9981	≥10	≥10
Brown 5T08	7	5-7	Grey 9958	7	5
Brown 5X08	7	5	Violet 886	3-5	NR
Green 606	5	3	Violet 8839	7	3-5
Green 650	≥10	≥10			

KEY: ≥ better than NR not recommended

15.4 APPENDIX IV - PERSPEX® FROM LUCITE® PRODUCT DATA SUMMARY

Property	Test Method	Units	Perspex	Perspex	Perspex	Perspex XT IM	
			GS	GS IM	XT	IM50	IM60
			000/0000	0M14	0X00		
General							
Relative Density	ISO 1183	-	1,19	1,18	1,19	1,17	1,16
Rockwell Hardness	ISO 2093-2	M Scale	102	98,5	101	65	45
Flamibility	DIN 4102	Class	B2	B2	B2	-	-
Flamibility	UL94		HB	HB	HB	-	-
Flamibility	BS476, Teil 7		3	3	4	-	-
Mechanical							
Tensile Strength	ISO 527 (a)	MPa	75	62	70	68	50
Elongation at Break	ISO 527 (a)	%	4	-	4	8	25
Flexural Strength	ISO 178 (b)	MPa	116	105	107	90	70
Flexural Modulus	ISO 178 (b)	MPa	3210	2960	3030	2500	2000
Charpy Impact Strength	ISO 179 (c)	kJ.m^{-2}	12	21,7	10	50	65
	ISO 179 (d)	kJ.m^{-2}	-	1,2	-	5	7
Izod Impact Strength	ISO 180/1A (d)	kJ.m^{-2}	-	-	-	5	7
Thermal							
Vicat-Softening Point	ISO 306A	°C	>110	>110	>105	>105	>105
Coefficient of Thermal Expansion	ASTM D696	$\times 10^{-5}, \text{K}^{-1}$	7,7	-	7,8	-	-

The above data represents typical results obtained using standard test pieces.

- a = 5 mm/min
- b = 2 mm/min
- c = un-notched
- d = notched

15.5 APPENDIX V - NAMES AND ADDRESSES OF RECOMMENDED SUPPLIERS

<p>1. Paint and screen ink suppliers</p> <p>Coates Lorilleux Ltd St Mary Cray Orpington Kent BR5 3PP Tel: +44 1689 894000 Fax: +44 1689 894020</p> <p>Sericol Ltd Pysons Road Industrial Estate Broadstairs Kent CT10 2LE Tel: +44 1843 866668 Fax: +44 1843 872074</p> <p>2. Suppliers of router machines</p> <p>Pacer Systems Ltd Gauntley Street Nottingham NG7 5HF Tel: +44 115 988 7777 Fax: +44 115 988 7788</p> <p>Spandex PLC 1600 Park Avenue Aztec West Almondsbury Bristol BS32 4UA Tel: +44 1454 616444 Fax: +44 1454 616777</p> <p>3. Suppliers of Tensol® cements and adhesives</p> <p>Bostik Ltd Ulverscroft Road Leicester LE4 6BW Tel: +44 (0)116/268 92 54 Fax: +44 (0)116/628 92 99</p>	<p>4. Suppliers of self-adhesives vinyl films</p> <p>3M United Kingdom PLC 3M House 28 Great Jackson Street Manchester M15 4PA Tel.: +44 (0)161/236 8500 Fax: +44 (0)161/236 4682</p> <p>5. Suppliers of lamps and electrical equipment</p> <p>Jerrard Bros. PLC Arcadia House Cairo New Road Croydon CRO 1XP Tel: +44 20 8251 5555 Fax: +44 20 8251 5500</p> <p>MacTac UK Ltd 4-6 The Britannia Trade Centre Ryehill Close Lodge Farm Northampton NN5 7UA Tel: +44 1604 756521 Fax: +44 1604 758150</p> <p>Philips Lighting Ltd OEM Division The Philips Centre 420-430 London Rd Croydon Surrey CR9 3QR England Tel: +44 20 8781 8009 Fax: +44 20 8665 5102</p> <p>Philips Lighting Ltd OEM Division BUILDING 6EL 1 P.O. Box 80020 5600 JM Eindhoven The Netherlands Tel: +31 4027 881 62 Fax: +31 4027 822 73</p>
--	---